

METAL-TECHNIK

PRODUCENT MASZYN ROLNICZYCH I KOMUNALNYCH

KATALOG CZĘŚCI ZAMIENNYCH ŁADOWACZA CZOŁOWEGO TYTAN MT 02

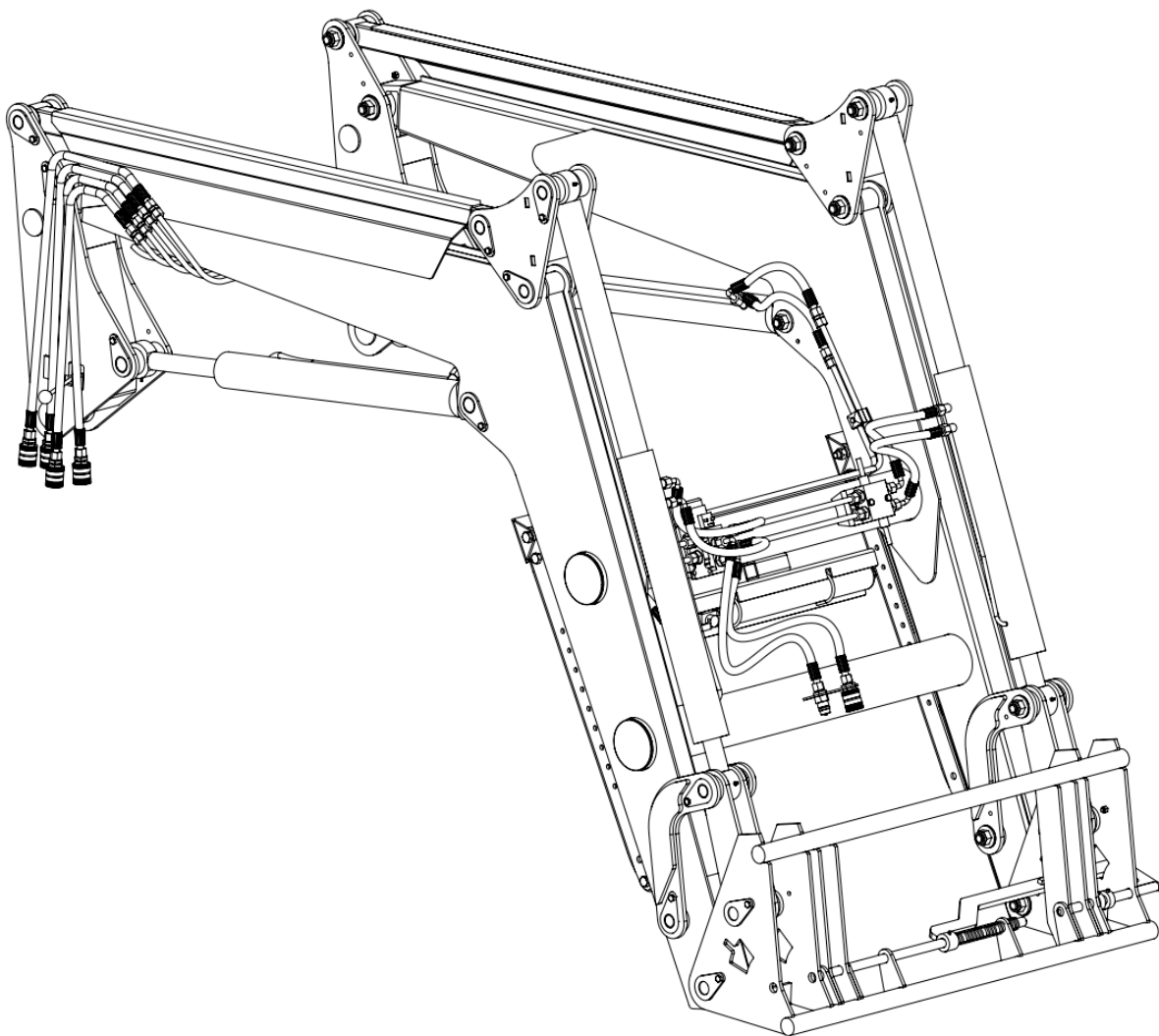

METAL-TECHNIK

PRODUCENT MASZYN ROLNICZYCH I KOMUNALNYCH

Gańkówka 12, 18-413 Miastkowo

Biuro Obsługi Klienta:

+48 662 004 976,

zamowienia@metal-technik.com

Reklamacje:

+48 668 873 759,

reklamacje@metal-technik.com

Informacja Techniczna:

+48 883 379 808,

+48 722 107 203,

technolog@metal-technik.com

technolog1@metal-technik.com

Serwis:

+48 601 912 164

LC.MT-02

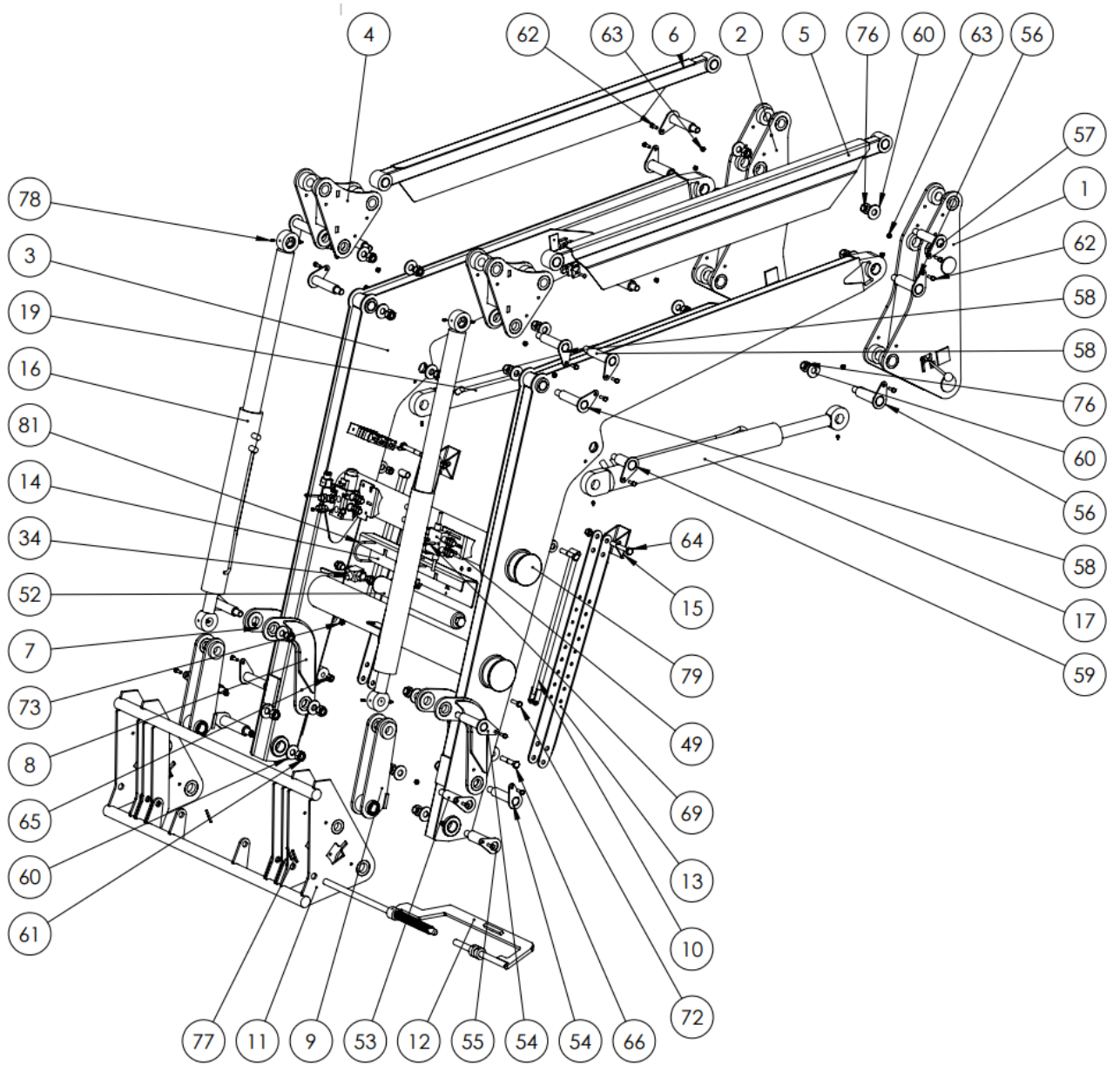

LC.MT-02

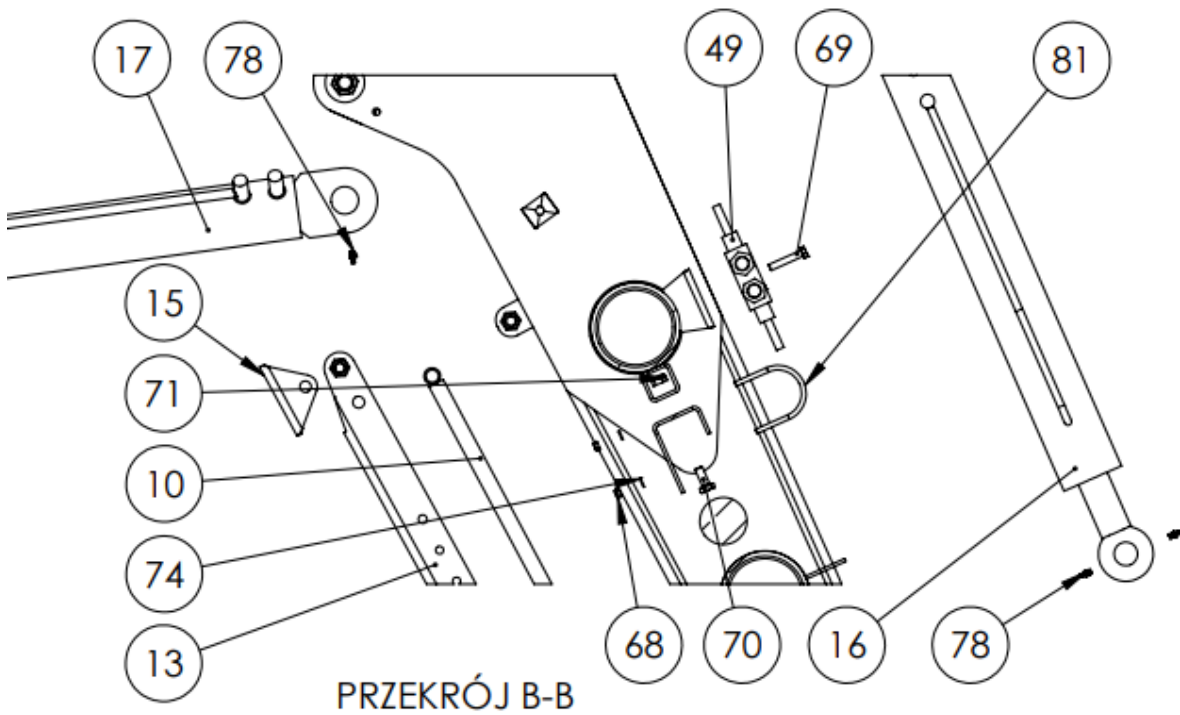
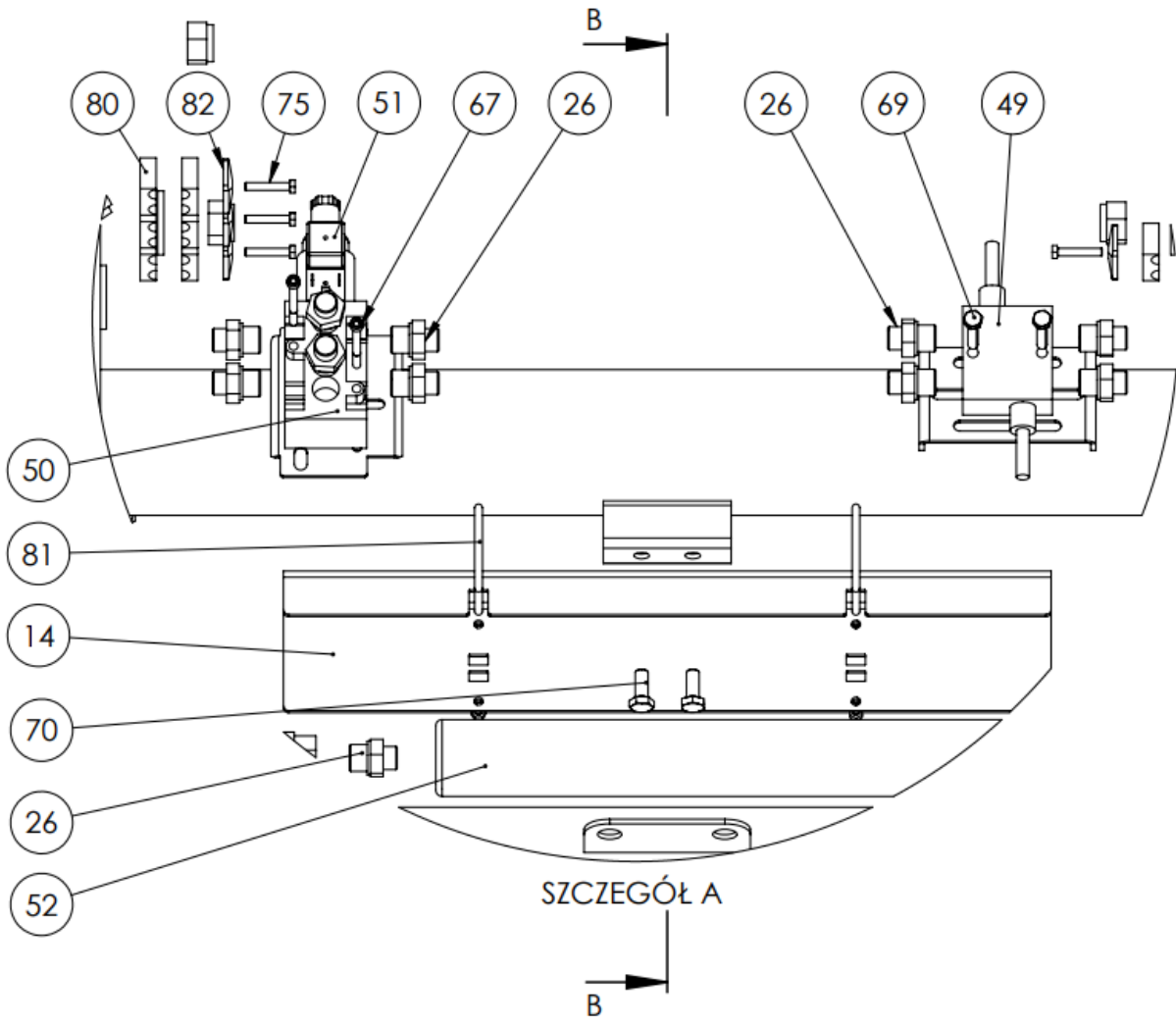

LC.MT-02

NR ELEMENTU	NUMER CZĘŚCI	OPIS	ILOŚĆ
1	LC.MT-02.02		1
2	LC.MT-02.03		1
3	LC.MT-02.01		1
4	LC.MT-02.04		2
5	LC.MT-02.05L		1
6	LC.MT-02.05P		1
7	LC.MT-02.06 P		2
8	LC.MT-02.06 L		2
9	LC.MT-02.07		2
10	LC.MT-02.09		2
11	LC.MT-02.RAMKA		1
12	LC.MT-02.ZATRZASK		1
13	LC.MT-02.35-06-02		2
14	WSPORNIK HYDROAKU		1
15	LC.MT-02.41-06-02		2
16	Siłownik UCJ 80-40-490		2
17	Siłownik 70.40.580 L		1
19	Siłownik 70.40.580 P		1
26	REDUKCJA 1-2xM18x1,5		12
34	Zawór kulowy dwudrożny		1
49	ZAWOR KRZYZOWY		1
50	ELEKTROZAWOR BADENSTNOST		1
51	WTYK ELEKTROZAWORU		1
52	hydroakumulator		1
53	Sworzeń fi30x130 T-Gm20 S-Ł		2
54	Sworzeń fi30x120 T-Gm20 S-Ł		4
55	Sworzeń fi35x130 T-Gm20 S-Ł		2
56	Sworzeń fi35x115 T-Gm20 S-Ł		4
57	Sworzeń fi30x115 T-Gm20 S-Ł		2
58	Sworzeń fi30x125 T-Gm20 S-Ł		6
59	Sworzeń fi35x75 T-Gm20 S-Ł		2

LC.MT-02

NR ELEMENTU	NUMER CZĘŚCI	OPIS	ILOŚĆ
60	Podkładka M20 DIN 9021		22
61	Nakrętka M20 DIN 985		10
62	śruba M8x25 DIN 933		22
63	nakrętka M8 DIN 985		24
64	śruba M14x2.0x100 DIN 931 8.8		2
65	nakrętka M14 DIN 985		6
66	śruba m14x80 DIN931		4
67	śruba M6x1 L75 DIN 912		2
68	nakrętka M6 DIN 985		6
69	śruba M8x45.step		2
70	śruba M10x1.5x25 DIN 933		2
71	nakrętka M10 DIN 985		2
72	ŚRUBA m10 x 1.5 x 40 DIN 933		2
73	Nakrętka M10 DIN 934		2
74	podkładka M6 DIN 125		4
75	śruba M6x35		7
76	NAKRETKA-M20x2,5		12
77	Kołek fi6x50DIN1481		3
78	SMAROWNICZKA M6 DIN71412A		12
79	Zaślepka fi114		4
80	uchwyt przewodów hydraulicznych		14
81	Opaska typ U M6		2
82	uchwyt podwójny DIN 3015 fi12 góra		7

LC.MT-02 Przewody

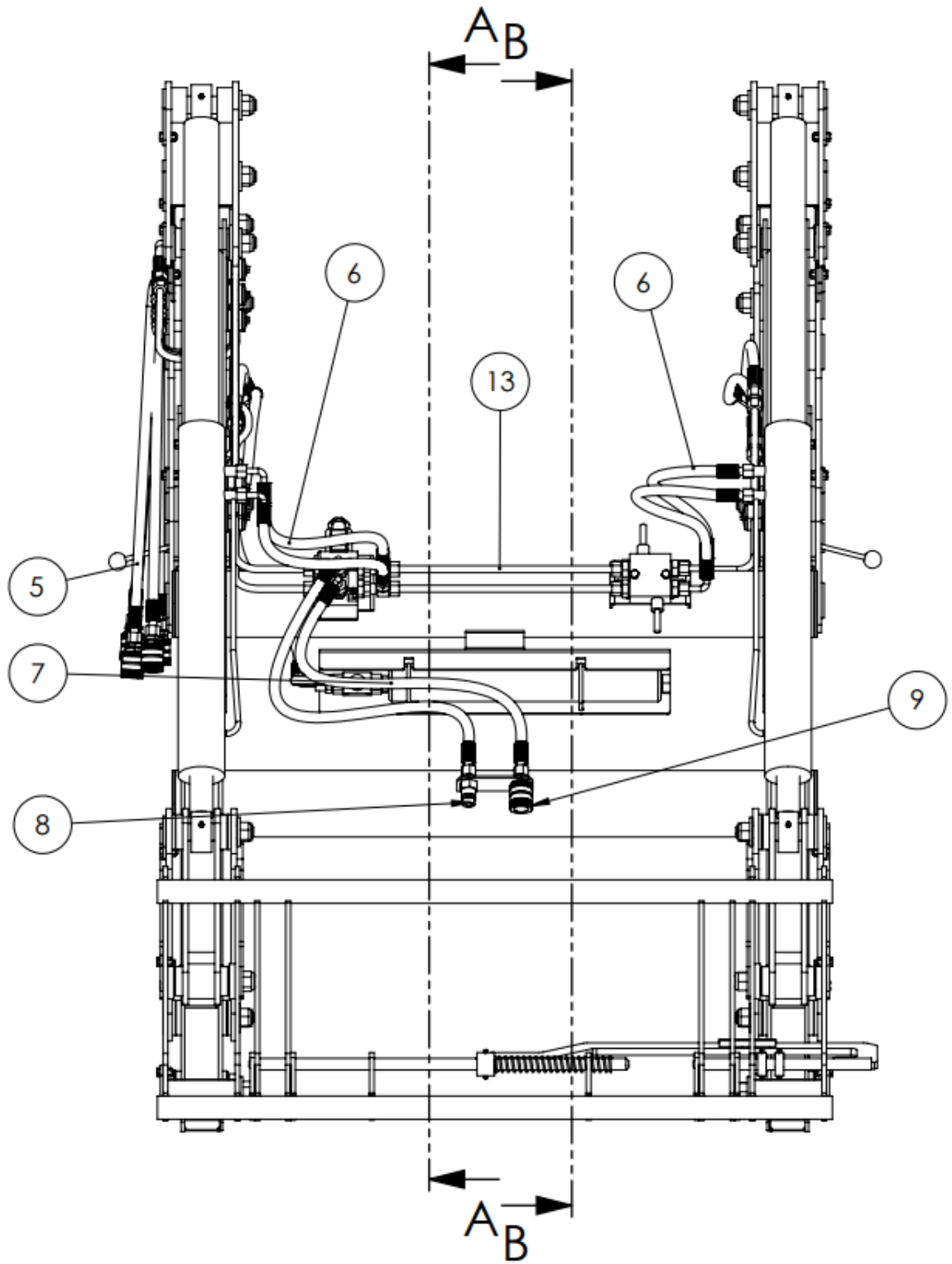

LC.MT-02 Przewody

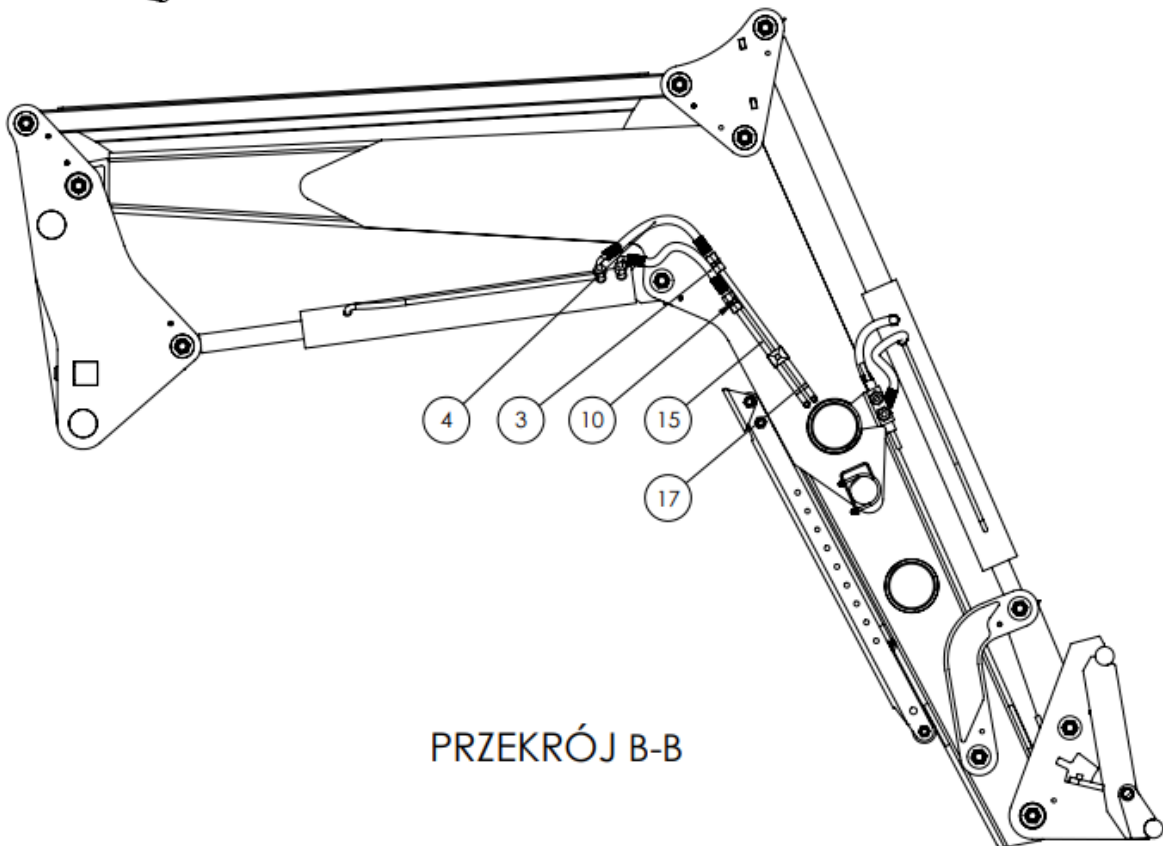
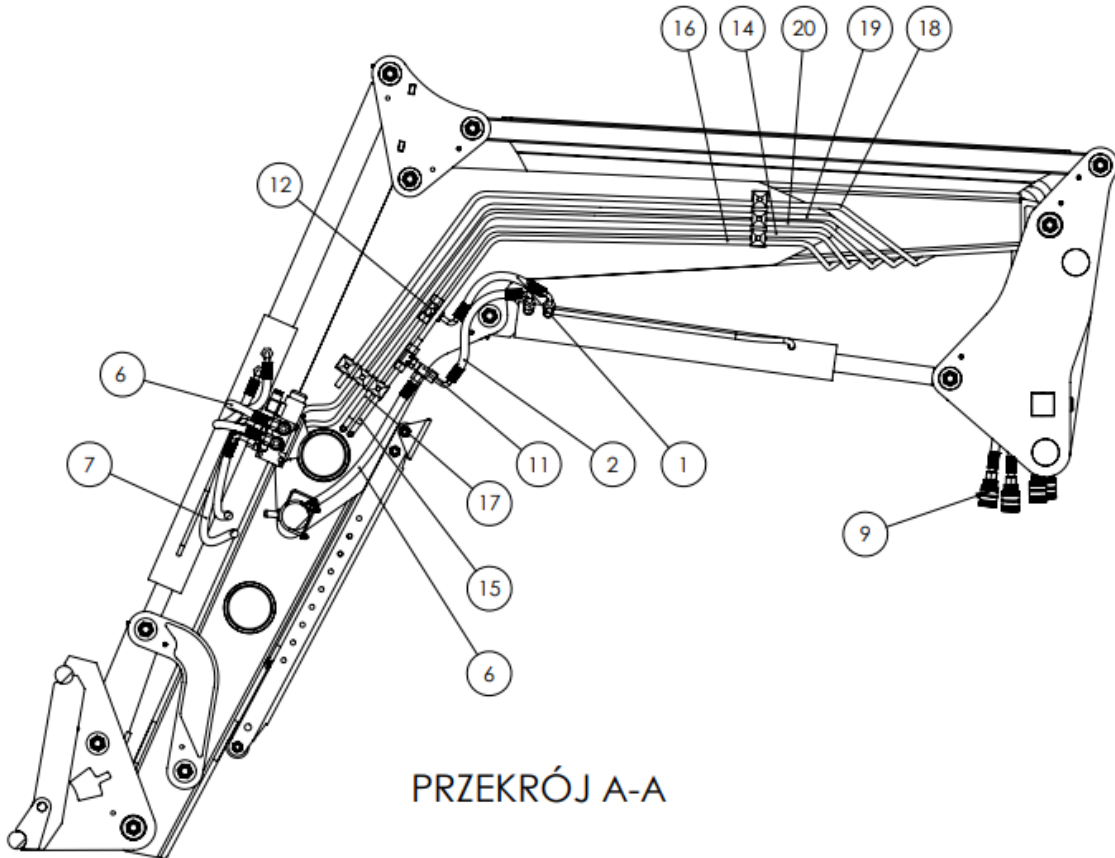

LC.MT-02 Przewody

NR ELEMENTU	NUMER CZĘŚCI	OPIS	ILOŚĆ
1	P12-P12 M18X1,5 DN10 IISN L320		1
2	P12-P12 M18X1,5 DN10 IISN L375		1
3	P11-P12 M18X1,5 DN10 IISN L415		1
4	P11-P12 M18X1,5 DN10 IISN L425		1
5	P11-P12 M18X1,5 DN10 IISN L900		4
6	P11-P11 M18X1,5 DN10 IISN L550		5
7	P11-P12 M18X1,5 DN10 IISN L660		2
8	szybkozłącze męskie M18x1,5		1
9	SZYBKOZŁACZE-ZENSKIE M18x1,5		5
10	złączka BB M18x1,5		6
11	TRÓJNIK ABB M18		3
12	TRÓJNIK BBB M18		2
13	Rurka hydrauliczna L370		2
14	Rurka hydrauliczna L1280		1
15	Rurka hydrauliczna L1300		1
16	Rurka hydrauliczna L1370		1
17	Rurka hydrauliczna L1500		1
18	Rurka przewodu elektrycznego L1700		1
19	Rurka hydrauliczna L1910		1
20	Rurka hydrauliczna L1925		1

LC.MT-02.02

LC.MT-02.03

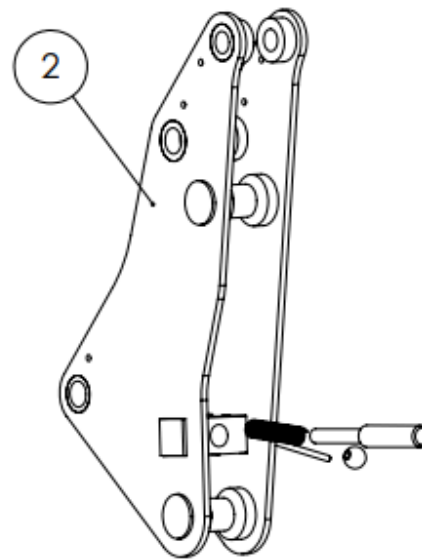
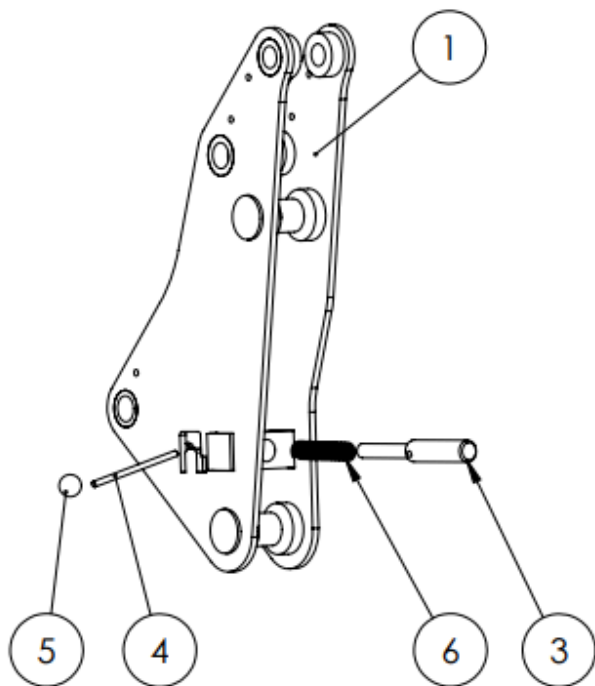

NR ELEMENTU	NUMER CZĘŚCI	OPIS	ILOŚĆ
1	LC.MT-02.02		1
2	LC.MT-02.03		1
3	LC.MT-02.43-29,5-02		2
4	LC.MT-02.42-08-02		2
5	GALKA		2
6	sprężyna L-110-D25-d2,5 DIN 2095		2

LC.MT-02.01

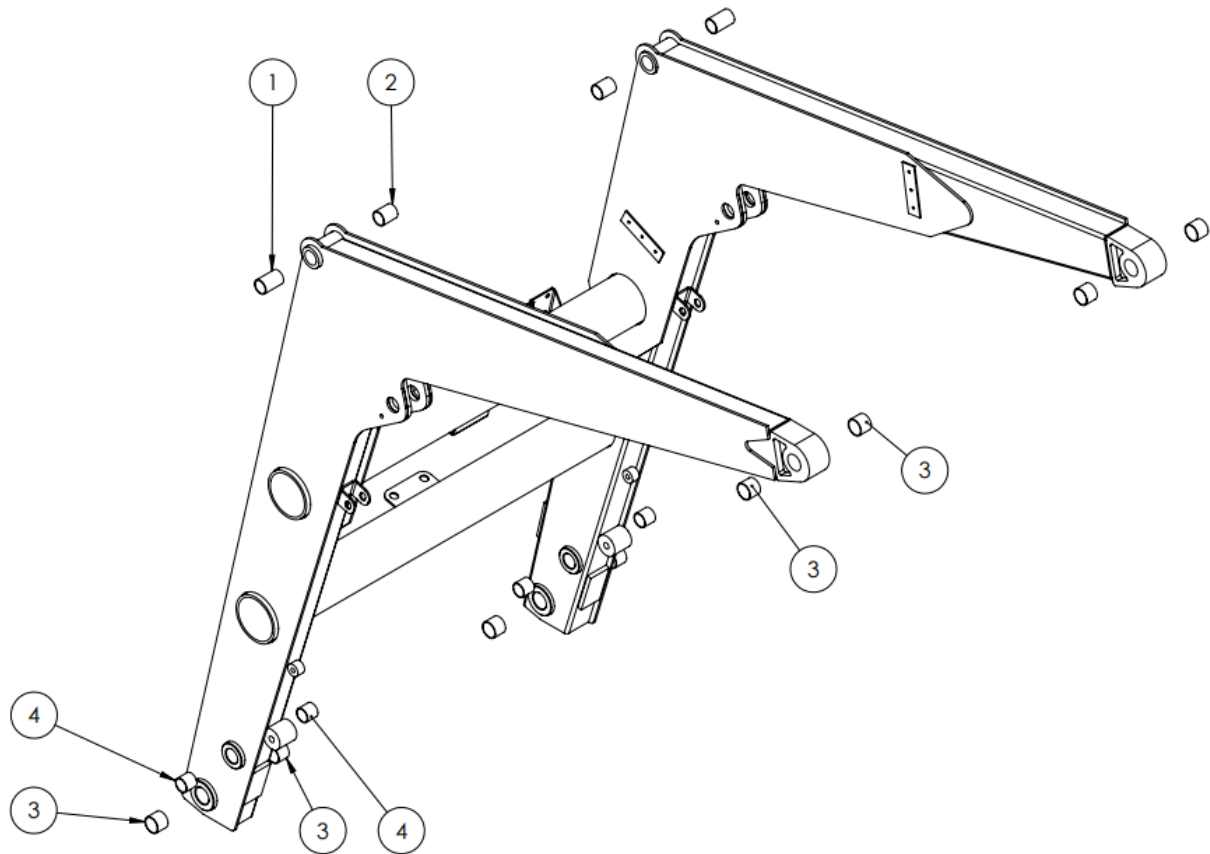

NR ELEMENTU	NUMER CZĘŚCI	OPIS	ILOŚĆ
1	LC.MT-02.GSM-3034-52,5		2
2	LC.MT-02.GSM-3034-40		2
3	LC.MT-02.GSM-3539-30		8
4	LC.MT-02.GSM-3034-30		4

LC.MT-02.04

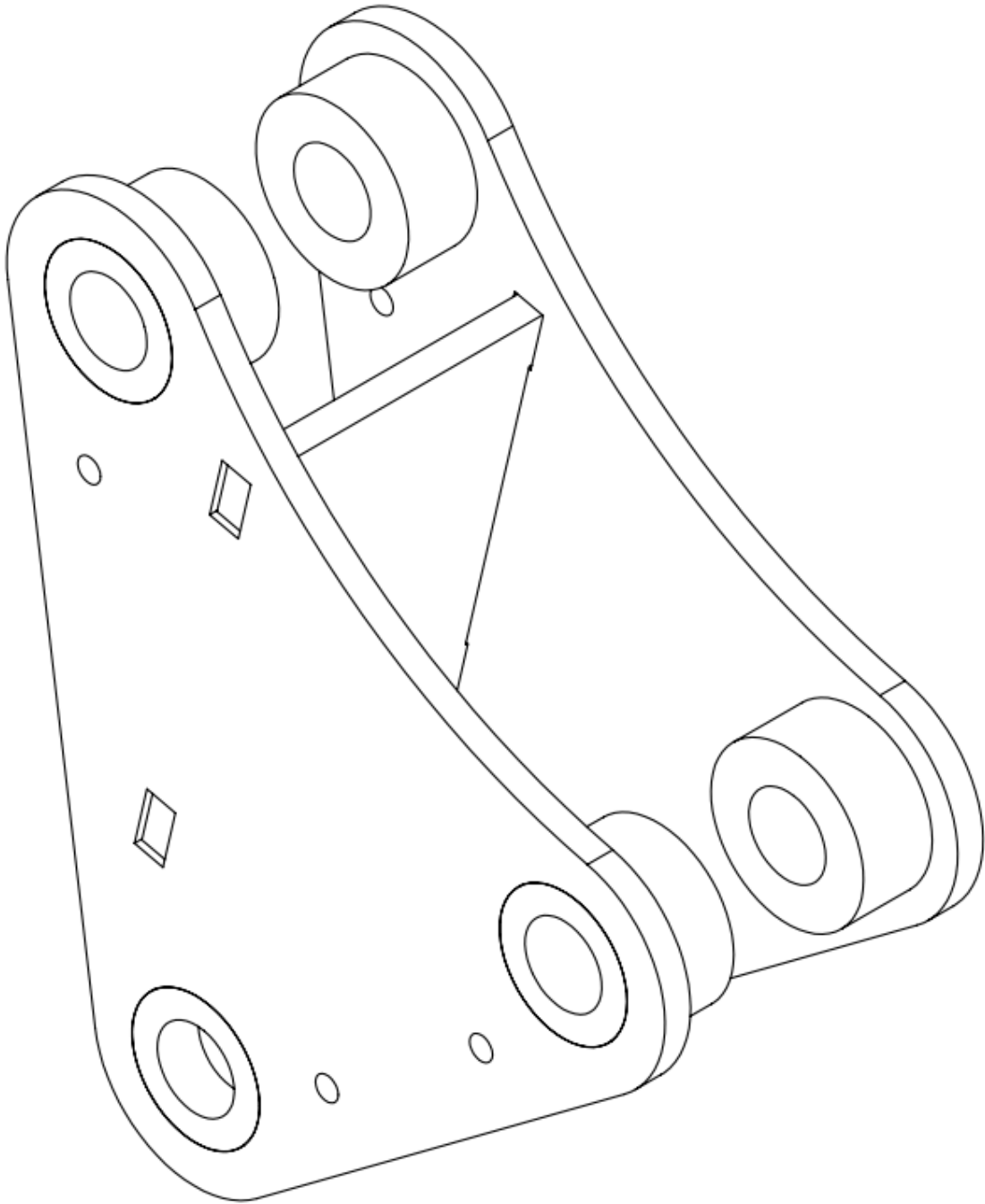

LC.MT-02.05L

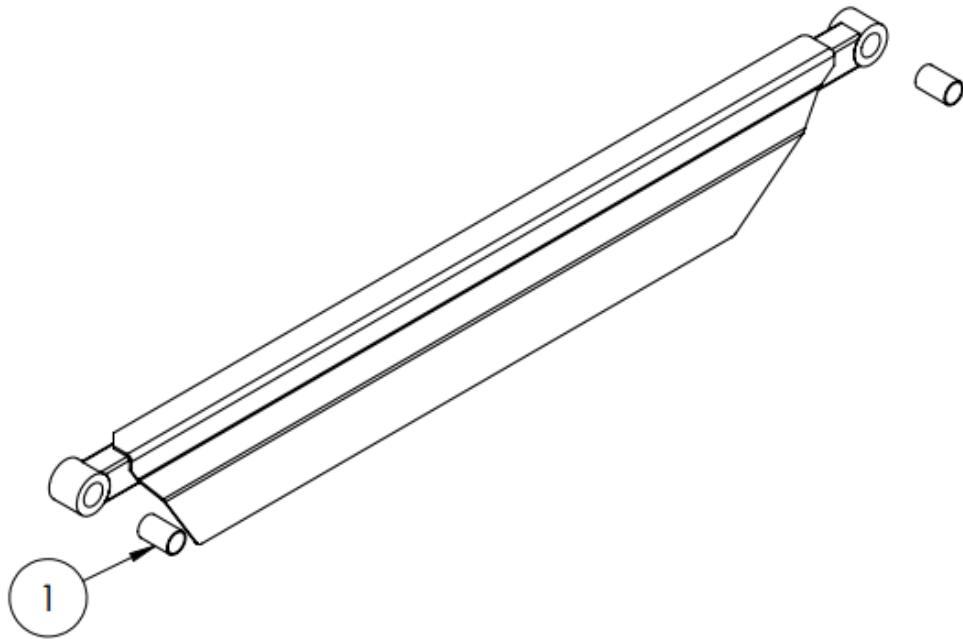

NR ELEMENTU	NUMER CZĘŚCI	OPIS	ILOŚĆ
1	LC.MT-02.GSM-3034-52,5		2

LC.MT-02.05P

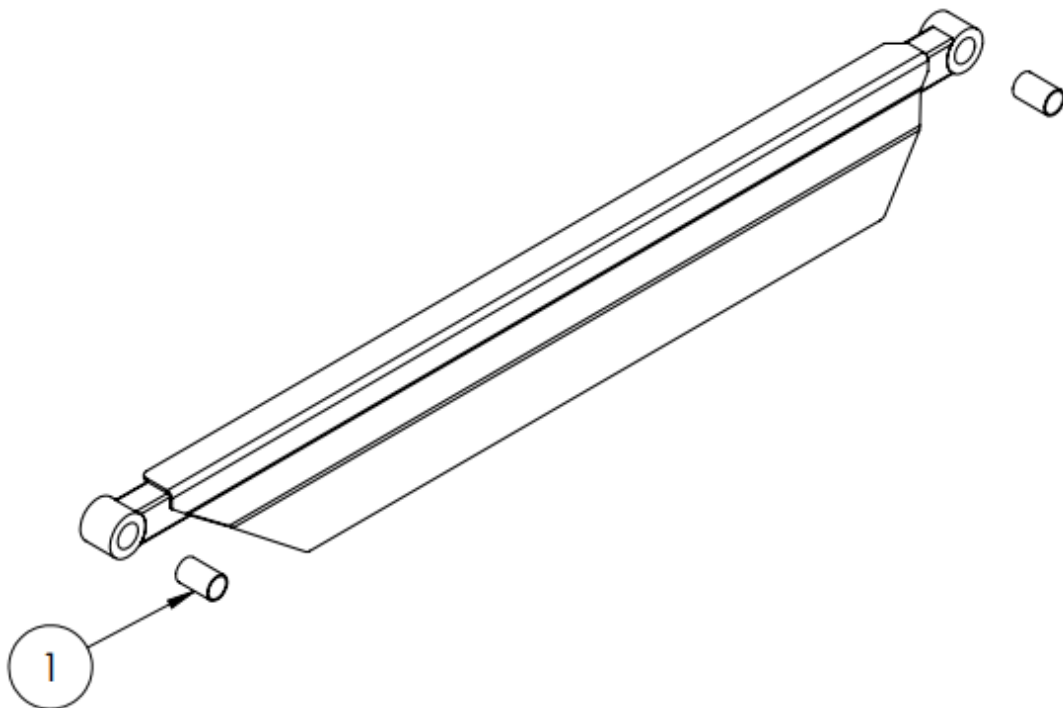

NR ELEMENTU	NUMER CZĘŚCI	OPIS	ILOŚĆ
1	LC.MT-02.GSM-3034-52,5		2

LC.MT-02.06L

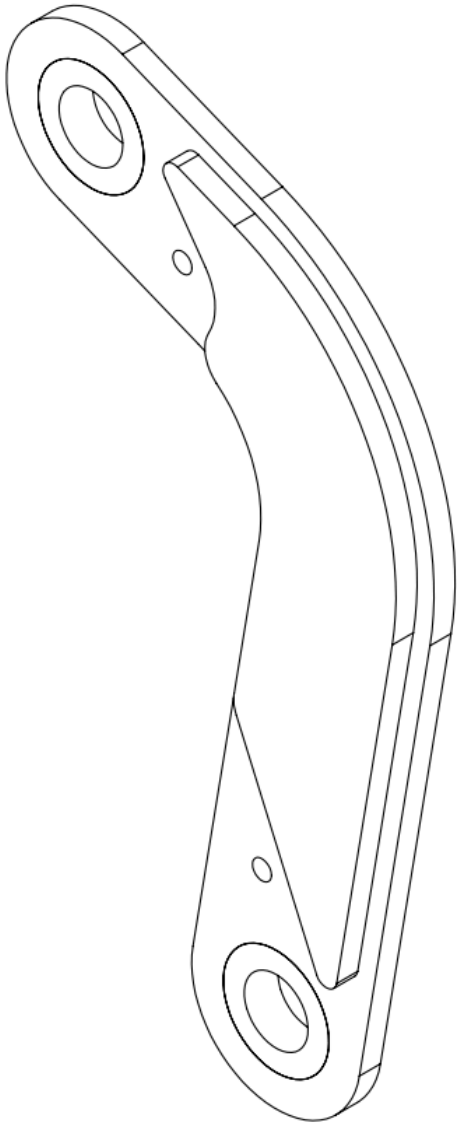

LC.MT-02.06P

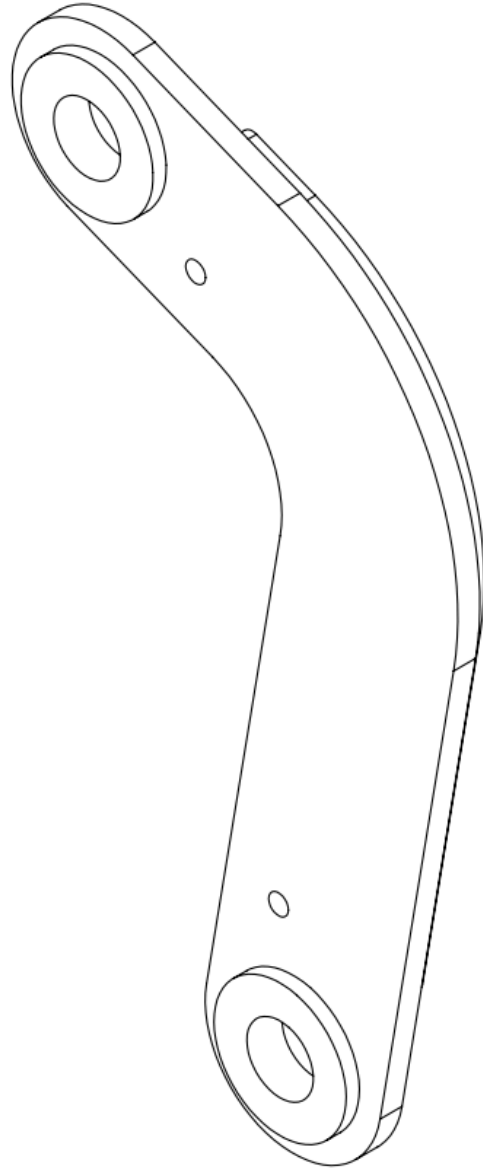

LC.MT-02.07

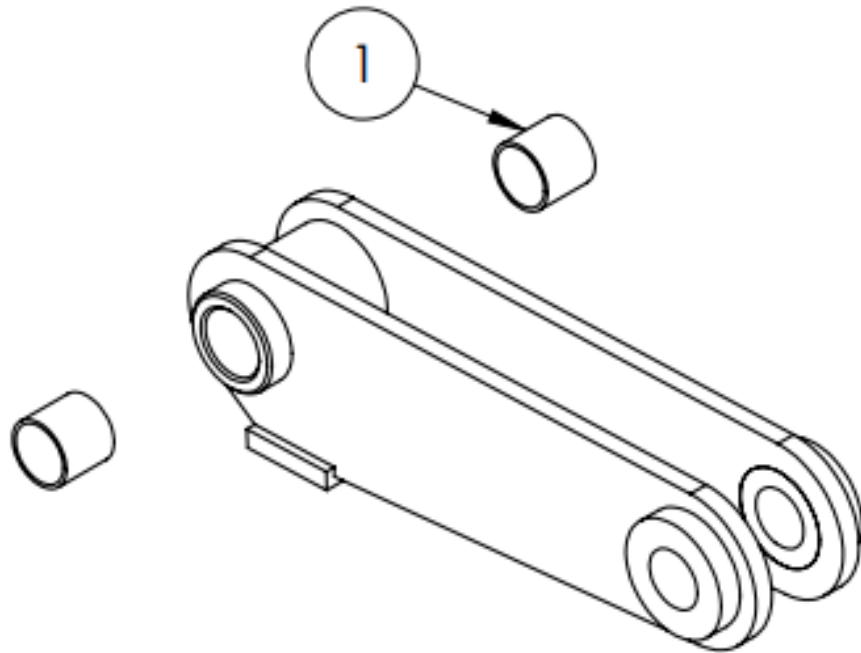

NR ELEMENTU	NUMER CZĘŚCI	OPIS	ILOŚĆ
1	LC.MT-02.GSM-3034-30		2

LC.MT-02.09

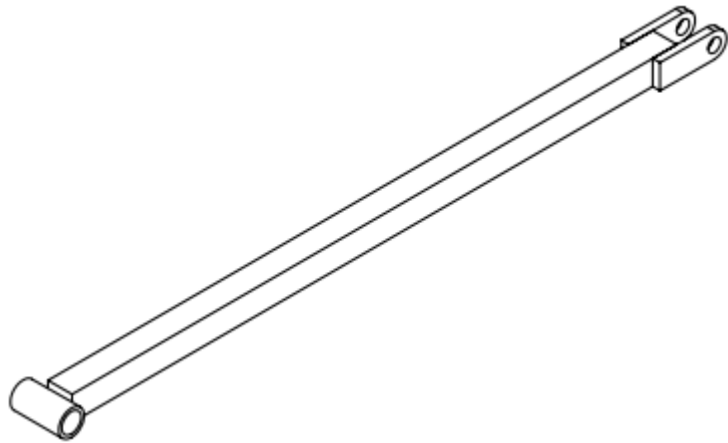

LC.MT-02.RAMKA

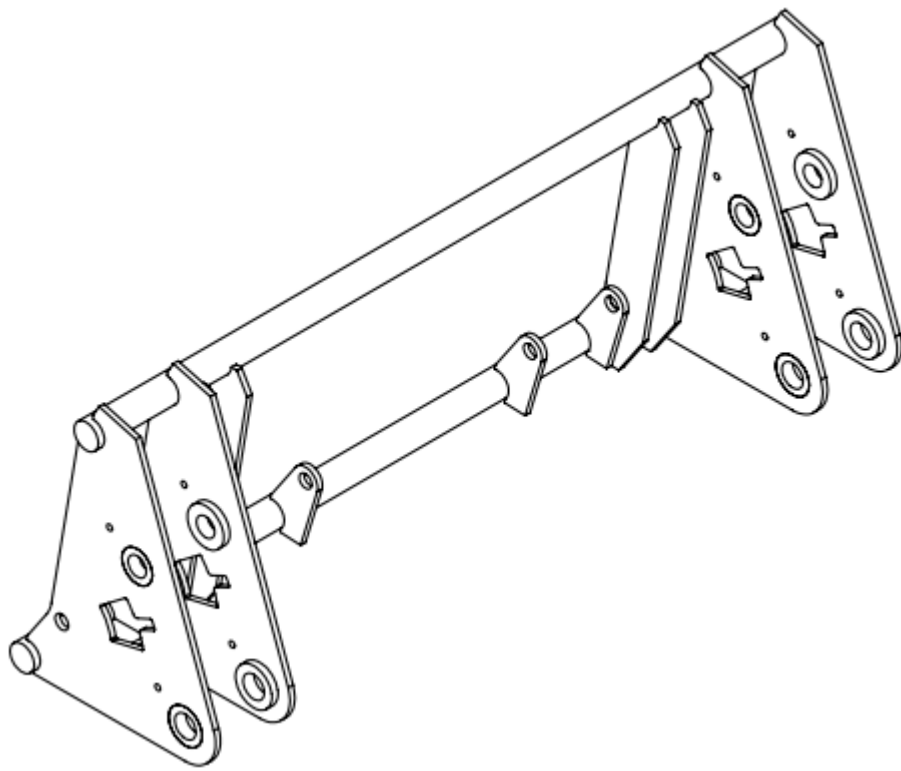

LC.MT-02.ZATRZASK

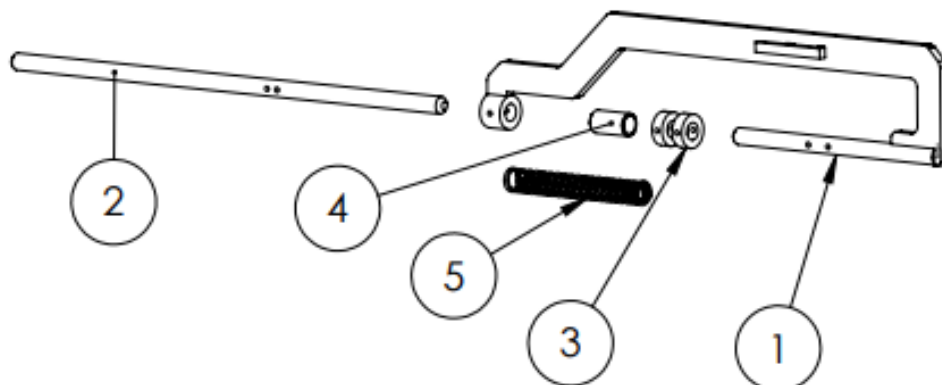

NR ELEMENTU	NUMER CZĘŚCI	OPIS	ILOŚĆ
1	LC.MT-02.ZAMEK		1
2	LC.MT-02.Z1-20-01		1
3	LC.MT-02.Z5-40-02		2
4	LC.MT-02.Z7-26,9-01		1
5	Spreżyna L200 D28,2 d3,2 DIN 17223		1

